



## **MANUAL INSTRUCTION**

Solid fuel cooker for central heating - SUPER-THERMO MAGNUM

**DEAR CUSTOMER,**

We appreciate your trust dedicated to us and your determination to buy our product.

You made a good choice, since this oven has technical characteristics which place it into top class, and you will be assured of it during exploitation.

Please, carefully read this manual before you start to use this cooker, since you will find tips and tricks for proper handling.

We believe that you will be one of the millions of satisfied customers of our products.

A.D. „Milan Blagojević“ Smederevo

## CONTENTS

Warning before use.....	1
Description.....	2
Installation.....	4
Installing cooker into the system of water heating .....	6
Managing operation of the cooker.....	10
Firing and ignition.....	11
Cleaning and maintenance.....	12
General notes.....	13
Advices for environmental protection.....	13

## **WARNING BEFORE USE**

To obtain proper operation of your cooker, it is important to read this manual and strictly observe directions for use and handling.

For combustion, use solid fuels like woods, briquettes and low-caloric coal. It is forbidden to put explosive devices and materials into the firebox or on the plate. It is forbidden to keep combustible materials in direct vicinity of the cooker.

For proper combustion, in normal operating mode, draft in the chimney should be 15-17 Pa. In case if draft is higher then 17 Pa, flap should be installed into the chimney.

It is necessary on regular basis to ventilate room in which cooker is located due to inflow of fresh air necessary for combustion.

Cooker parts get heated to high temperatures during operation and appropriate attention is necessary during handling. Do not allow children to handle and play in vicinity of the cooker.

Only spare parts approved by the manufacturer may be installed on the cooker. Do not make any changes to the cooker.

At the first firing up, slight smoking may occur, especially from the surface of the plate. It is common appearance which originates due to combustion of deposits on the plate surface (anti-corrosive protection, color, dust....). Room in which cooker is located should be ventilated during first firing up.

Do not allow part of the cooker to become incandescent.

On the same chimney, do not install any device which uses gas as fuel.

During firing up, use protective gloves since door handles and vessels are heated.

### **DO NOT USE COOKER:**

- If it is not connected to installation
- If installation is in lack of water
- If installation is broken

Upon installation, observe all national and local provisions for installation.

**In case of non-observance of this manual, manufacturer will not accept any responsibility for damages on the cooker.**

## COOKER DESCRIPTION

Central heating cooker **Super Thermo Magnum** is produced and tested according to the European standard EN 13240. Layout of the cooker with its components crucial for operation is given on the picture 1. Central heating cooker **Super Thermo Magnum** has boiler of 19 liters capacity made of boiler metal sheets, with thicknesses anticipated by the standards. This manufacture increases life span of the boiler. Connections to water are 1".

Working plate is consisted of gray cast iron plate (fig. 1, pos. 1) with gray cast iron smoke exhaust (fig. 1, pos. 7) which is mounted onto the plate with two screws.

Firebox door (fig. 1, pos. 8) are made of gray cast iron and has thermalproof transparent glass (fig. 1, pos. 9). Ashtray door (fig. 1, pos. 11) is made of gray cast iron too and has auxiliary air flow regulator (fig. 1, pos. 12).

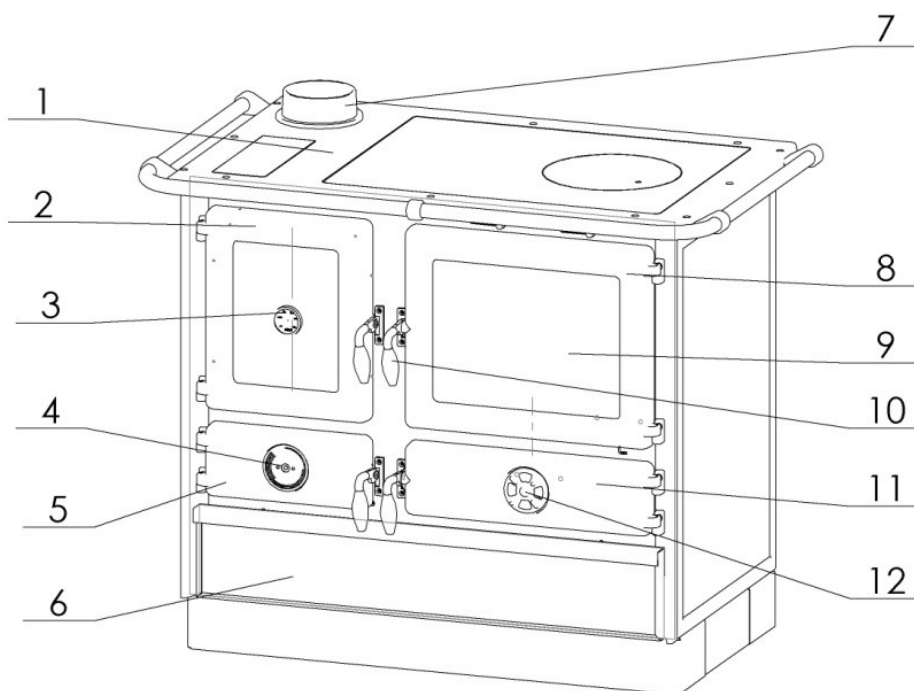

Fig. 1. Integral parts of Super Thermo Magnum cooker

- |                            |                          |
|----------------------------|--------------------------|
| 1 – Cast iron plate        | 7 – Smoke exhaust        |
| 2 – Oven door              | 8 – Firebox door         |
| 3 – Thermometer            | 9 – Firebox door glass   |
| 4 – Thermoregulator button | 10 – Handles             |
| 5 – Door                   | 11 – Auxiliary regulator |
| 6 – Drawer                 |                          |

This cooker is intended for heating of residential areas. Integral part of the installation is safety thermal exhaust valve which serves as safety thermal valve

against eventual overheating. We recommend safety thermal valve **Caleffi 544 1/2** shown on fig. 2.

**Comment:** Safety thermal valve is not part of the product and will not be delivered with cooker. Guarantee for the boiler is valid exclusively with built-in thermal valve.



Fig. 2: Safety thermal valve Caleffi

## TECHNICAL CHARACTERISTICS

Table 1. Technical characteristics

No	Technical characteristics	
1.	Nominal thermal power (kW)	21
2.	Efficiency (%)	87
3.	Thermal power given to water (kW)	13
4.	Thermal power given to room (kW)	8
5.	Dimensions WxDxH (mm)	1060x650x860
6.	Dimensions of firebox WxDxH (mm)	400x430x310
7.	Amount of water in boiler (l)	19
8.	Fume outlet diameter (mm)	130
9.	Connections for water pipe (")	1
10.	Draft (Pa)	15
11.	Temperature of smoke gasses (°C)	240
12.	Maximal water temperature (°C)	80
13.	Recommended fuel	beech wood
14.	Consumption of fuel at nominal power (kg/h)	5.2
15.	Maximal working pressure (bar)	3
16.	Dust emission (mg/m <sup>3</sup> )	39
17.	Contents of CO	0.07

## INSTALLATION

Do not put the cooker in direct vicinity of wooden elements, cooling devices, plastic parts of the furniture and other combustible materials, since it creates high working temperature which is distributed at the exterior of the cooker (at the combustion of fuel). The least distance between cooker and surrounding elements is 50 cm, and combustible materials 80 cm.

If surface on which cooker is to be positioned is made of easily combustible material (wood, warm floor, laminated floor...) it is necessary to install metal sheet protection - lateral width 10 cm, in front 50 cm.

Due to its weight, it is necessary to install cooker on the floor with appropriate carrying capacity. If latter does not fulfill requirements, please take proper measures to achieve it (e.g. distribution of weight).

Cooker is to be connected with chimney through flue pipes and via connection on the back side of cooker, in order to provide adequate sealing and smoke flow from cooker to the chimney. Flue pipe may not be installed too deeply into the chimney to avoid reduction of cross-section of the surface thus impairing draft in chimney. Do not use reducers which would reduce cross-section of the smoke exhaust pipe (flue pipe).

Cooker requires intake of fresh air into the room in which it is installed, whereat surface of the opening for intake of fresh air may not be smaller than  $0,4 \text{ dm}^2$ . Device for intake of fresh air is to be mounted outside collective room for ventilation which must be secured with doors and grid.

Ventilators which work in the same room in which cooker is mounted may create disturbances with the cooker operation. Also, all devices or air conditioning which make sub-pressure in the room in which cooker is installed must be adjusted not to make decompression which disables normal operation of the cooker.

Prior to installation of the cooker, check draft in the chimney since it is one of the key factors of proper operation. Draft depends on accuracy of the chimney and meteorological conditions. One of the simplest aspects for checking of the draft in the chimney is using candle flame, as illustrated in the figure 2. Candle flame is to be offered to connection opening of the chimney and, if it sways towards opening, draft is satisfactory (fig. 2b). Weak swaying of the flame is indicator of weak draft (fig. 2a).

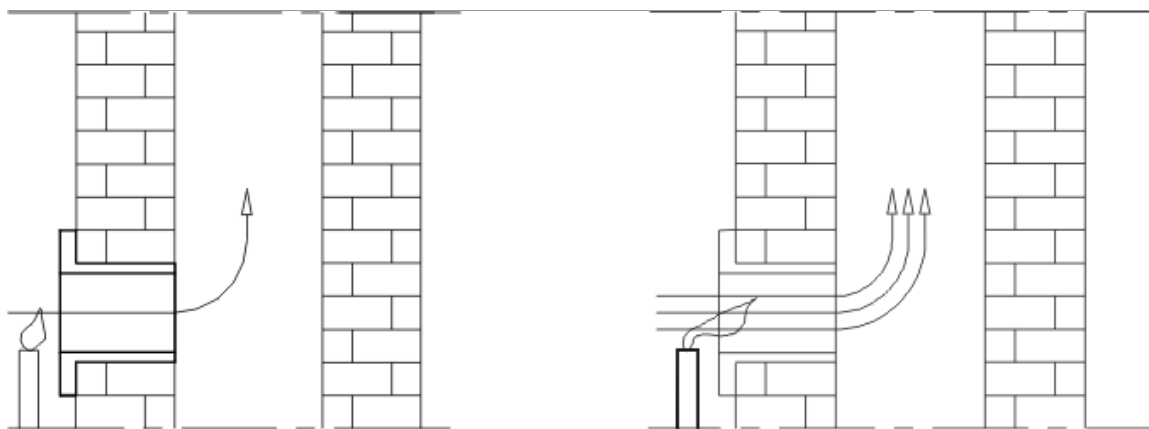

Fig. 2a.

Fig. 2b.

If draft in the chimney is weak (Fig. 2a), check accuracy of chimney. Chimney should be located within interior of an object, and if it's on external walls of an object, it is recommended to insulate the chimney.

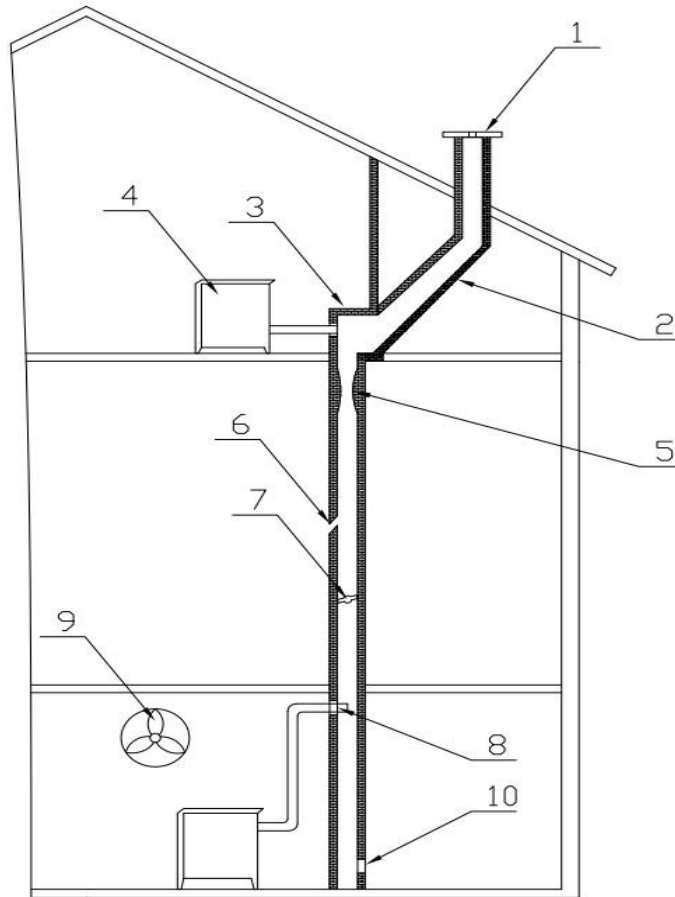

Fig. 3

Defaults of the chimney may be (fig. 3):

1. Chimney is lower than top of the roof, small cross section of the exit
2. Too large slope
3. Abrupt alteration of the direction of smoke channel,
4. Cooker or other device connected to the same smoke channel,
5. Bulges in the smoke channel,
6. Cranks,
7. Foreign body or deposited smut,
8. Too deep installed pipe,
9. Ventilator or other device which creates sub-pressure in the room
10. Leaky or open aperture for cleaning



## INSTALLING COOKER INTO THE SYSTEM OF WATER HEATING

- for intake and output of water into the system of central heating, connections of of 1" on boiler are anticipated.
- cooker may be mounted on closed or open system of central heating.

### Mounting to closed system of central heating

One of the way of proper installation is shown on the picture 5.

- safety valve must be installed on the vicinity of boiler and must be set to pressure of max. 3 bar (boiler is tested for 4 bar). Connection guide of safety valve must be as shorter as possible and may not be capable for closing. This guide, also, may not contain any valve or any other fixing.
- Closed expansion vessel is to be installed next to the boiler ad safety valve is short. Volume of this vessel is to be determined based on capacity of boiler, thereat propotion of 1kW:1l is valid.
- It is obligatory to install safety thermal valve of boiler on anticipated place. We recommend safety thermal valve Caleffi 544.

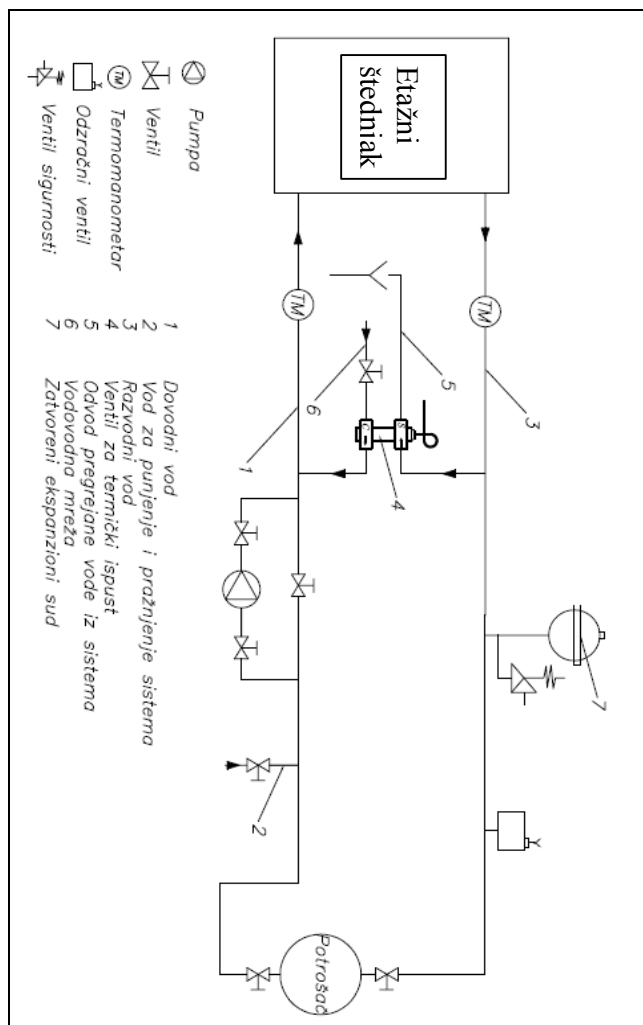

Fig. 5

Diagram of closed system of central heating

### Mounting to open system of central heating

One of the aspects of installation is shown on fig. 6.

At this system, starting guide is to be installed with safety distribution guide of expansion vessel and valve of boiler, and on starting guide valve of boiler is to be installed, as well as pump and valve. Directly below open expansion vessel there must be short connection of safety distribution guide and safety return guide, which in winter prevents freezing of water in expansion vessel.

On safety distribution and safety returning guide there may not be any fixture.

Expansion vessel itself must have overflow duct as shown on diagram 7. Volume of expansion vessel is to be determined by the pattern:

$V = 0,07 \times V_{\text{water}}$ , (l), where  $V_{\text{water}}$  is water volume and entire power plant.

Open expansion vessel is to be installed vertically above the highest heating body. At open heating system, gravitaion system of heating is possible.

**Note:** Mounting of heating and putting into operation of entire system should be exclusively carried out by expert who guarantees proper work of entire heating system. In case of weakly designed system and eventual omissions upon works by mentioned person, complete material responsibility shall be borne exclusively by person who carred out installation of heating system, not manufacturer, representative or retailer of the boiler.

### **Important**

- Installation of cooker should be carried out by expert according to appropriate project design. Cooker construction enables connection to open or closed heating system. All connections must be well sealed and tightened. Prior to operation, complete installation should be inspected with water under pressure of 3 bar.
- upon installation of safety valve, pay attention to direct connection with aqueduct and sewage, and if valves (taps) are always open.
- If reinforced hose is used for connection with drainage opening, it must be removed from back side of cooker.

**At the first firing up**, it is necessary to inspect accuracy of valve by short-term overheating up to 100°C, and then inspect accuracy of air flow regulator and installation for distribution of hot water to radiators, as well as radiators themselves.

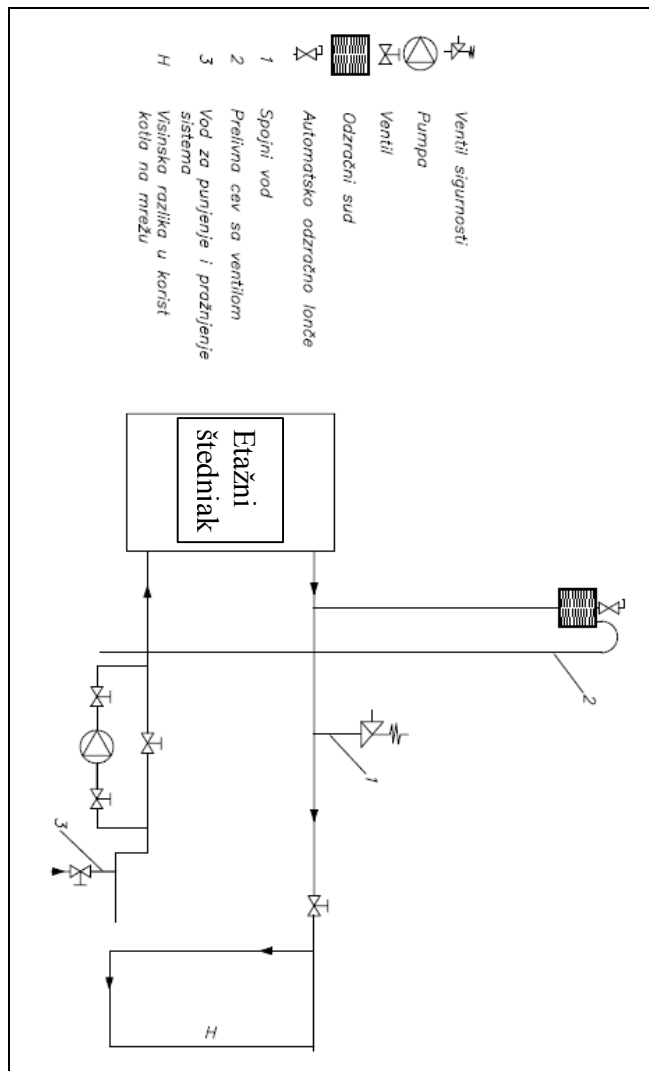

Fig. 6  
Diagram of open system of central heating

## FIRING UP AND IGNITION

Prior to the first ignition, wipe all enameled surfaces of the cooker with dry mop to avoid combustion of dirt on the cooker and creation of unpleasant scents.

Firing up in the firebox should be carried out as follows:

- open firebox and ashtray door and pull primary air handle,
- put into the firebox some firing materials (chopped wood on non-greasy and crumpled paper),
- fire up,
  - ashtray door should be left open until stable flame occurs, and after closing, intensity of the burning should be regulated on the air flow regulator, (fig. 1, pos. 3)
- close firebox and ashtray door,

- after creation of basic cinder, put into the firebox some bigger pieces of woods or coal and close firebox door. If briquettes are used, you must wait all quantity of fuel to get ignited then to reduce air flow to half.
- at adding fuel, open firebox door (fig. 1, pos. 1) for only few degrees, wait for 4-5 seconds, then open it wide very slowly. Do not open it abruptly, because when flame in the firebox is too strong, it may effuse into the room.

By regulation of air flow in the cooker, you set temperature, power and pace of fuel combustion, and it is to be carried out by turning air flow regulator on the ashtray door (fig. 1, pos. 4). Cooker has secondary air flow regulation due to improvement of combustion and maintaining firebox glass clean. By combining primary air through regulator on the ashtray door and secondary air via buttons above firebox door desired combustion is achieved.

Cooker has auxiliary tools which serve to facilitate maintenance of the cooker.

Woods and briquettes are recommended for burning.

**Do not use fuel oil, gasoline or similar as fuel for the cooker, since use of liquid fuels creates conditions for damaging of cooker and possible explosion.**

#### **Attention!**

- Do not use organic residues, food residues, plastic objects, combustible and explosive materials as fuel, since their combustion disturbs proper operation of the cooker and may cause damages and pollution of environment.
- Increased external temperatures may cause weak draft in the chimney, thus it is recommended more frequent burning in smaller quantities.
- Use of the cooker in cases when meteorological conditions are bad and in case of strong wind, it is to be maintained on proper sub-pressure in the chimney. In indicated cases, smoke may return into the room in which cooker is located. Firing up is protracted in such cases.

We recommend burning on each 1h with the height of the fuel in the firebox up to 15 cm with crosswise positioning of the woods due to higher draft.

Upon each filling, it is recommended to let the cooker to burn at least 30 minutes with maximal power, in order to burn all evaporable ingredients which are the reason of creation of condensate in the cooker in this stage of combustion.

For proper operation of the cooker, it is necessary to:

- regularly clean cooker and chimney,
- regularly ventilate rooms due to good combustion,
- regularly remove ash from ashtray,
- regularly remove deposited gravel and unburned materials from the grid, using cleaning accessories.

## MANAGING OPERATION OF THE COOKER

Start firing up with moderate fire in terms of avoiding thermal shocks.

Following quantity of woods is to be inserted only when previous quantity gets burned.

Do not allow clogging of the grid with ashes and unburned fuel. Clean the grid.

Open the door slowly and carefully, not abruptly, enabling equalization of pressures in the firebox and room, otherwise, it may cause occurrence of smoke in the room.

Cooker is designed and provided for operation with constantly closed firebox door, except during filling with fuel. Do not open door unnecessarily.

Wood must be with maximal 20% humidity for maximal burning performance.

Otherwise, tar and gases occurs which create creosote with water vapor. If creosote occurs in larger quantity, fire may occur in the chimney.

Fire in the chimney will be easily recognized as follows: characteristic sound which comes from the chimney like loud hoot, visible flame which comes from chimney, high temperature of surrounding walls and characteristic smell of flare.

If fire occurs, take following steps:

- Immediately call fire department
- Suppress oxygen inflow into the chimney and turn off the cooker
- Do not put anything in chimney and look after fire not to extend to the wooden construction or some other combustible material in vicinity.
- **NEVER extinguish the chimney with water or to pour water in the cooker**
- Fire in the chimney may be extinguished only with the device with dry powder
- Water may be used only for surrounding materials
- Do not cool surrounding walls with water

Prior to second filling, clean the grid with auxiliary tools to avoid clogging of fresh air intake. Regularly clean ashtray, taking care top leave enough space for the ash. For maintenance of necessary nominal power, firebox periodically is to be filled with indicated amount of fuel.

Cooker is not intende to work in the mode of continuing burning or heat accumulation.

Agility of combustion, as well as amount of heat by the cooker, depend on the amount of primary combustion air which is to be brought into the area below the grid. Regulation of primary air amount is achieved automatically via draft regulator **Rathgeber** (fig. 7).

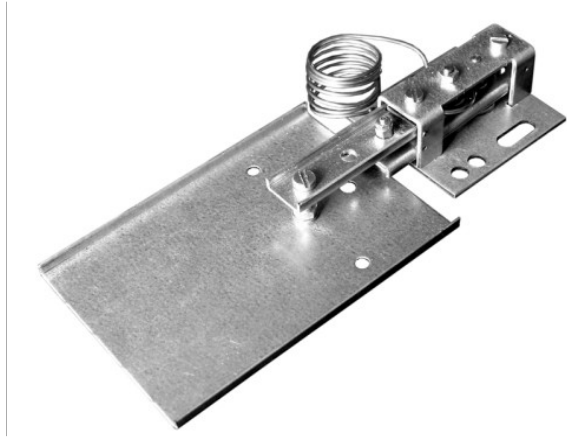

Fig. 7

During firing up, turn regulator button into position of maximally open flap in the direction depicted on fig. 8. During operation, depending on temperature, regulator flap will open and close automatically. If lower temperature than set is desired, turn regulator button in desired position of minimal open flap, then regulator flap is closed.

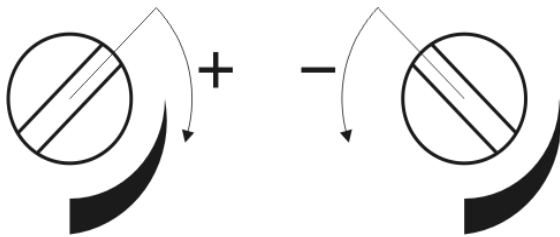

Fig. 8

If there are disturbances in burning (weak fuel, non-remedied inaccuracies for proper operation) use auxiliary regulator, located on front side of ashtray door (fig. 1 pos. 12), and bring some primary air, to improve combustion.

## CLEANING AND MAINTENANCE

Regular and proper cleaning enables proper operation and longer life span of the cooker.

**Cleaning of external surfaces** – with soft cloth which will not damage the cooker surfaces. Chemical cleaning agents may be used and don't damage surfaces of the oven. Do not clean colored and enameled surfaces with abrasive agents.

**Cleaning of internal surfaces** –when clean, use protective gloves.

Clean internal walls of the firebox against deposited smut, collect small and unburned particles from the grid, clean ashtray and deposited ash within the cooker.

**Cleaning of glass surfaces** – friebox glass gets dirty during operation. For cleaning, use soft detergents. Do not use abrasive agents since glass surface may get damaged. Clean glass when it's cold.

**Cleaning and maintenance of the chimney**- cleaning and control of the chimney is recommended at least once a year as well as after longer inactivity. Regular maintenance and control of the chimney will prevent origination of fire and weak operation.

## IRREGULARITIES IN OPERATION AND TROUBLESHOOTING

In the following table, there are most frequent operating irregularities and troubleshooting.

Table: Display of the most frequent irregularities, possible causes and troubleshooting.

Problem	Possible cause	Remedy
Cooker weakly heats and cooks	<ul style="list-style-type: none"> <li>Irregular handling</li> <li>Bad chimney</li> </ul>	<ul style="list-style-type: none"> <li>Carefully read and observe manual</li> <li>In case if all conditions from the manual are fulfilled and problem still persists, call service</li> </ul>
Problems with firing up	<ul style="list-style-type: none"> <li>closed air intake regulator</li> <li>wet woods</li> <li>lack of oxygen</li> </ul>	<ul style="list-style-type: none"> <li>open air intake regulator and provide primary air intake</li> <li>use dry woods</li> <li>ventilate the room to provide fresh air</li> </ul>
Smoke is coming below the plate	<ul style="list-style-type: none"> <li>closed air intake regulator</li> <li>lack of draft</li> <li>unclean ash from the grid</li> </ul>	<ul style="list-style-type: none"> <li>open air intake regulator and provide primary air intake</li> <li>carefully read manual and apply tips for providing air flow</li> <li>clean the grid</li> </ul>
Firebox door glass has tar after a short period of operation	<ul style="list-style-type: none"> <li>wet woods</li> <li>too much fuel</li> <li>lack of draft</li> <li>closed secondary air intake</li> </ul>	<ul style="list-style-type: none"> <li>use dry woods</li> <li>see recommended amount of fuel for combustion given in the manual</li> <li>check connection with the chimney</li> <li>carefully read manual and apply tips for providing secondary air</li> </ul>

## GENERAL NOTES

If all installation recommendations, operating and cleaning regulation given in this manual are met, cooker represents proven and safe household device.

Prior to installation, remove the package. Take care of possible injuries since wooden battens on packaging have nails. Dispose of plastic bag in the proper place according to the local regulations. Old cooker which will not be used in the future should be disposed of according to the local regulations.

All claims, evaluated as defects or weak functioning of the cooker should be reported to manufacturer or authorized service via phone or in written form with fiscal bill attached. All contact information is given at the end of this manual.

All defects on the cooker are to be repaired exclusively by the manufacturer.

If unauthorized personnel make any servicing or repairs or changes, owner of the cooker will lose the right to service guaranteed by the manufacturer.

Purchase of spare parts is to be done exclusively through manufacturer, based on positions and figures or their names in this manual.

Manufacturer shall not bear any liability if purchaser does not observe instructions and installation manual.

## **ADVICES FOR ENVIRONMENTAL PROTECTION**

### **Packaging**

- Packaging material may be 100 % recycled.
- At disposing of the waste, observe local regulations.
- Packaging material (plastic bags, parts of polystyrene-styropor etc.) should be kept out of reach of children, since it is potential source of danger.
- Pay attention to safety during removal and disposing of wooden battens since they are nailed.

### **Product**

- Device is made of materials which may be recycled. At the disposal of waste, Observe local environmental laws.
- Use only recommended fuels.
- It is forbidden to burn inorganic and organic waste (plastic, cardboard, textile, oiled wood etc.), since within combustion it discharges cancerous and other harmful materials.

A.D. "Milan Blagojević" Smederevo  
Đure Strugara 20  
11300 Smederevo  
tel: 026 633 600  
026 633 601  
fax: 026 226 926  
Servis: 026 633 670  
026 231 597  
e-mail: [servis@mbs.rs](mailto:servis@mbs.rs)  
[www.mbs.rs](http://www.mbs.rs)